

CABLE INSTALLATION GUIDE.

1. INSTALL COMPONENTS INTO LID.
(USE 1553WTS100 #2 X 3/16" PLASTITE SELF-TAPPING SCREW NOT SUPPLIED.)
TORQUE SCREWS TO 15-20 cN-m [21-28 oz-lbf]

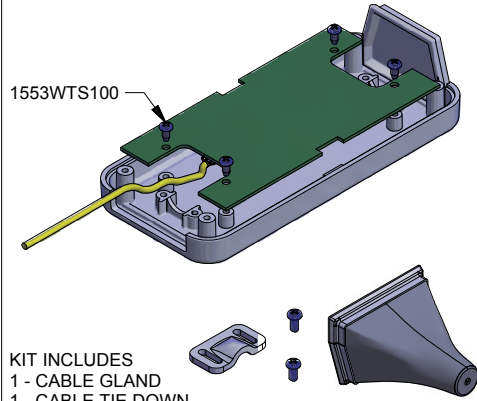

KIT INCLUDES
1 - CABLE GLAND
1 - CABLE TIE DOWN
2 - #2 X 1/4" SELF - TAPPING SCREW

2.

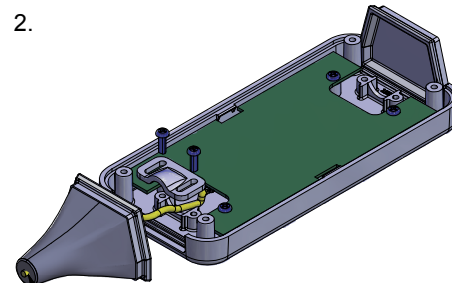

PUSH A 2MM - 6MM OUTER DIAMETER CABLE THROUGH THE CABLE GLAND.

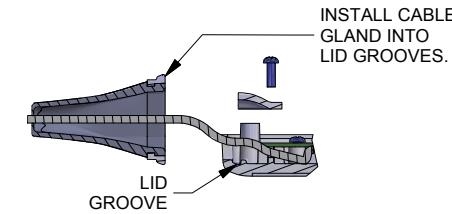

INSTALL CABLE GLAND INTO LID GROOVES.

LID GROOVE

3.

CABLE TIE ORIENTATION

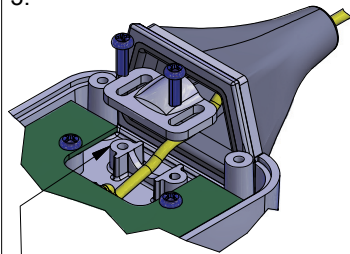

ORIENT CABLE TIE DOWN AS PER OPTION 1 OR 2, THEN LIGHTLY TIGHTEN SUPPLIED SCREWS. SLIDE THE TIE DOWN TOWARDS CABLE GLAND TO CLAMP WIRE. THEN TORQUE SCREWS TO 20-25 cN-m. [28-35 oz-lbf]

OPTION 1
CABLE OD
6mm - 3mm

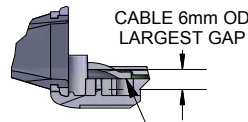

CABLE 6mm OD
LARGEST GAP

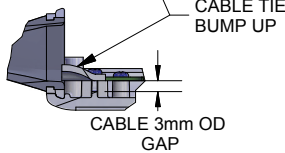

CABLE 3mm OD
SMALLEST GAP

OPTION 2
CABLE OD
3mm - 2mm

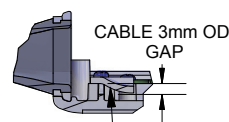

CABLE 3mm OD
LARGEST GAP

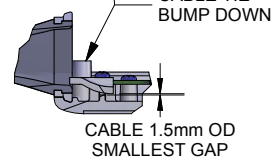

CABLE 1.5mm OD
SMALLEST GAP

4. INSTALL THE BOTTOM HALF OF THE ENCLOSURE TO THE RECOMMENDED TORQUE OF 15-20 cN-m [21-28 oz-lbf]

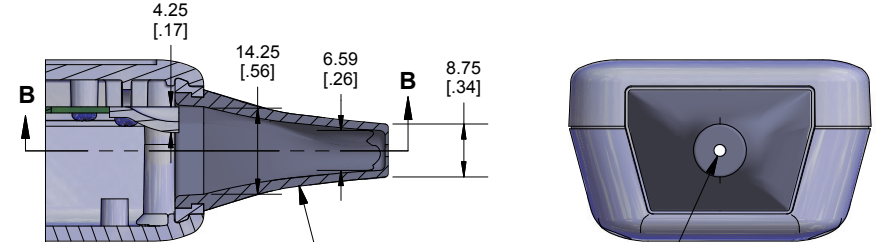
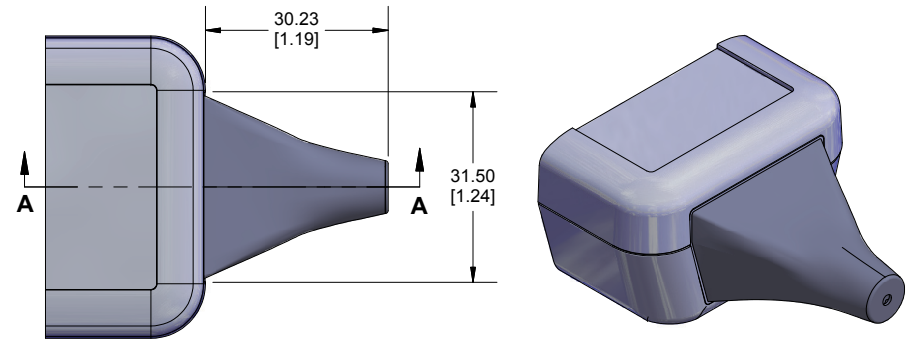
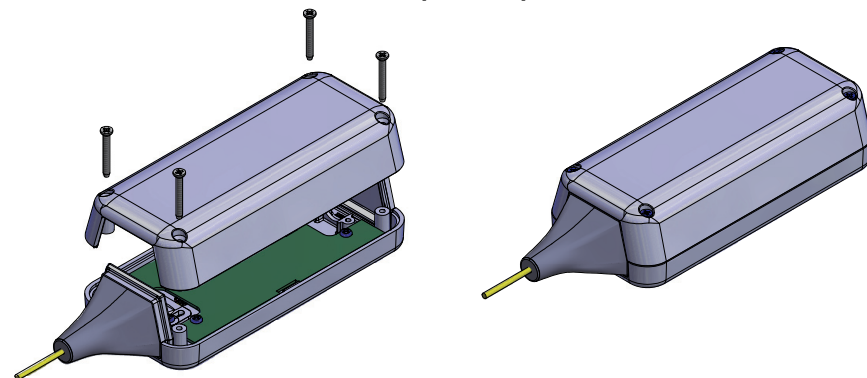

SECTION A-A

ACCEPTS A 2MM - 6MM OUTER DIAMETER CABLE

CABLE GLAND IS MADE FROM FLAME RETARDANT (UL94-V0) FLEXIBLE TPE & (UL94-V0) POLYCARBONATE MATERIAL

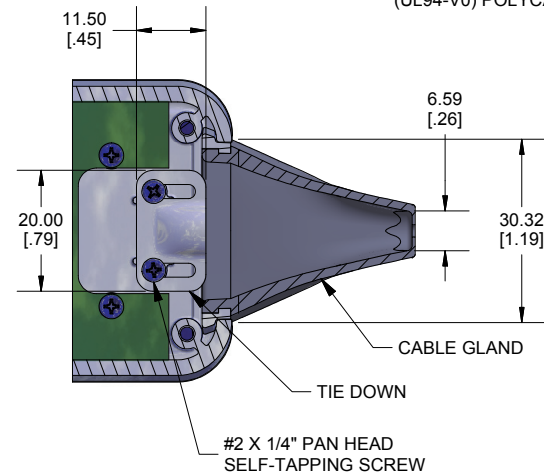

SECTION B-B

#2 X 1/4" PAN HEAD SELF-TAPPING SCREW

NOTE
Purchased assembly includes cable gland, tie down and 2 tie down screws. Cable gland molded from PC (UL94-V0) plastic and TPE (UL94-V0). Tie down molded from PC (UL94-V0). PCB Layout Drawings and 3D Models also available. Refer to enclosure drawing for dimensions

1552	
1552 ACCESSORIES	
1552D Cable gland Kit	1552DPGKITGY (Grey)
	1552DPGKITBK (Black)

HAMMOND MANUFACTURING
1552D CABLE GLAND KIT
INSTRUCTIONS
www.hammondmfg.com

REV 15.10.2019